

Aeroquip ProCrimp™ 1390 Crimp Machine Operator's Manual

Table of Contents

| | |
|---|-------|
| Safety Instructions | 2 |
| Specifications | 3 |
| Accessories | 3 |
| Setup and Installation | 3 |
| Operating Instructions | |
| Loading and Unloading Die Cages | 4 |
| Operating the Keypad | 4-5 |
| Entering a Number into the Display | 5 |
| Storing a Number from the Display | 5 |
| Recalling a Preset into the Display | 5 |
| Programmable Retract Stop | 5 |
| Adjustable Back Stop | 5 |
| Crimping Procedures | 6 |
| Calibration | 7 |
| Maintenance | |
| Intervals | 8 |
| Machine Maintenance Procedures | 8 |
| Die Cage Maintenance Procedures | 8 |
| Troubleshooting Tips | 9 |
| Crimp Machine Parts Breakdown | 10-12 |
| Die Cage Parts Breakdown | 12 |
| Electrical Schematics | 13-14 |
| Hydraulic Schematic | 14 |

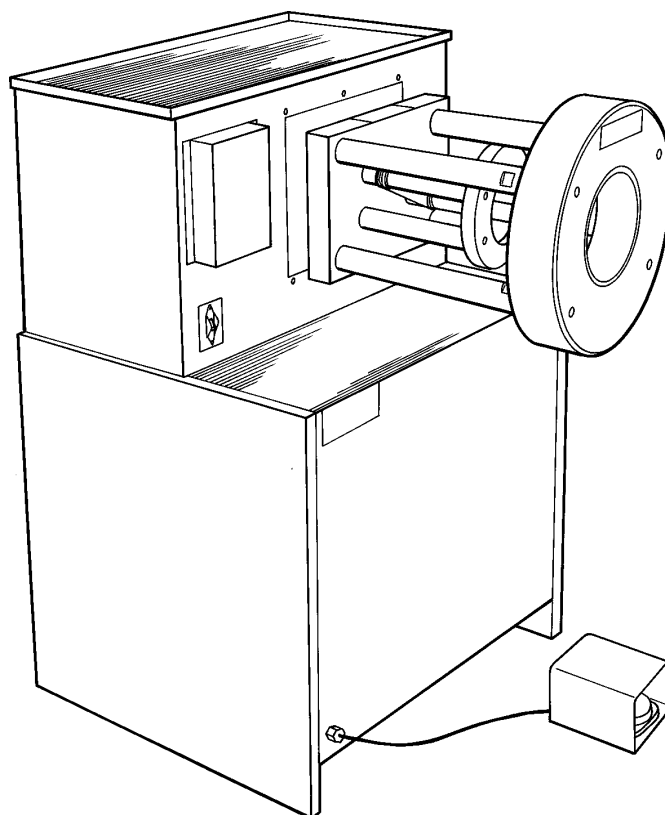



WARNING

Failure to follow Aeroquip process and product instructions and limitations could lead to premature hose assembly failures, resulting in property damage, serious injury or death.

Aeroquip fitting tolerances are engineered to match Aeroquip hose tolerances. The use of Aeroquip fittings on hose supplied by other manufacturers and/or the use of Aeroquip hose with fittings supplied by other manufacturers may result in the production of unreliable and unsafe hose assemblies and is neither recommended nor authorized by Aeroquip.

Read and understand the operator's manual before attempting to operate any equipment.

Aeroquip hereby disclaims any obligation or liability (including incidental and consequential damages) arising from breach of contract, warranty, or tort (under negligence or strict liability theories) should Aeroquip hose, fittings or assembly equipment be used with the hose, fittings or assembly equipment supplied by another manufacturer, or in the event that product instructions for each specified hose assembly are not followed.

Safety Instructions

1. **PREVENT UNAUTHORIZED OPERATION.** Do not permit anyone to operate this equipment unless they have read and thoroughly understand this manual.
2. **WEAR SAFETY GLASSES.**
3. **AVOID PINCH POINTS.** Do not rest your hand on the crimp ring. Keep your hands clear of all moving parts. Do not allow anyone, other than the operator, close to the equipment while it is in operation.
4. **MAINTAIN DIES WITH CARE.** Dies used in the FT1390 crimp machine are hardened steel, offering the best combination of strength and wear resistance for long life. Hardened dies are generally brittle, and care should be taken to avoid any sharp impact. Never strike a die with a hardened instrument.
5. **USE ONLY SPECIFIED AEROQUIP PRODUCTS.** Make hose assemblies using only Aeroquip hose and fittings specified for this assembly equipment.
6. **VERIFY CORRECT CRIMP DIAMETERS.** Check and verify correct crimp diameters of all fittings after crimping. Do not put any hose assemblies into service if the crimp diameters do not meet Aeroquip crimp specifications.
7. **Make sure all dies are completely in place and the cage is positioned properly on the pressure plate.**
8. **DO NOT OVER PRESSURIZE.** Do not exceed the 10,000 psi hydraulic pressure supplied to the machine. This setting is preset at the factory and should not require adjustment.

NOTE: All components used to connect the pump and crimp cylinder must meet the criteria set forth in Material Handling Institute Specification #IJ100 for hydraulic jacking applications.
9. **DIE CHANGE.** Do not insert/remove dies while the power is on.
10. **SECURE THE EQUIPMENT TO A STABLE WORK SURFACE.** Prior to operation, secure the crimp machine to a stable work surface to prevent the equipment from tipping.
11. **UNPLUG THE POWER SUPPLY WHEN NOT IN USE.**
12. **KEEP YOUR WORK AREA CLEAN.** Cluttered areas and workbenches invite accidents.

Specifications

Electrical Requirements:

- FT1390-115 110 to 120-Volt AC single phase 60 Hz
 circuit with a minimum of 20 amps
- FT1390-23050 ... 208 to 230-Volt AC single phase 50 Hz
 circuit with a minimum of 15 amps

Crimp Machine Dimensions:

- Width 29 inches
- Depth 28 inches
- Height 49 inches
- Weight 825 pounds

Production Capacity:

- All Aeroquip MatchMate Plus™ braided and spiral hose through -32 size
- Flat field crimp through -16
- Barrel field crimp through -20
- Flat single skive 1- & 2-wire braid crimp through -32
- Flat single skive 4-wire spiral crimp through -32
- Internal skive fittings
- Air conditioning hose fittings
- OTC flat crimp or OTC beer can crimp fittings

NOTE: A positive-stop backstop is required to crimp Aeroquip 2807, 2808, FC186, FC465, FC469 and FC505 hose styles.

Setup and Installation

1. Secure the Aeroquip ProCrimp 1390 crimp machine to the floor using the holes provided in the corners of the crimp machine base.
2. Remove the plug from the hydraulic reservoir vent port, and replace it with the vent cap that is supplied with the unit.



CAUTION: Failure to do so will cause cavitation and damage to the pumping mechanism. Hand tighten the vent cap.

3.  CAUTION: Provide electrical service with a dedicated circuit (per the crimp machine electrical requirements) in order to eliminate the possibility of a low-voltage situation.
4. Never use an extension cord. Always plug the unit directly into the power outlet.

Accessories

Crimp Die Cage Storage Cabinet

Aeroquip recommends that crimp die cages be kept free of dust or dirt. An optional wall-mountable cabinet is offered which has the capability to store nine crimp die cages.

Part Number FT1283

Die Cages

| | |
|-------------------|-----------------|
| Part Number | FT1307-200-M070 |
| | FT1307-200-M090 |
| | FT1307-200-M120 |
| | FT1307-200-M150 |
| | FT1307-200-M180 |
| | FT1307-200-M210 |
| | FT1307-200-M240 |
| | FT1307-200-M280 |
| | FT1307-200-M320 |
| | FT1307-200-M370 |
| | FT1307-200-M420 |
| | FT1307-200-M465 |
| | FT1307-200-M520 |
| | FT1307-200-M550 |
| | FT1307-200-M570 |
| | FT1307-200-M630 |
| | FT1307-200-M690 |

Additional die cages are required for internal skive and special application hoses.

Operating Instructions

Loading and Unloading Die Cages

To load the die cage, press and hold the RETRACT switch until the crimp cylinder reaches the "full retract" position and stops. The die cage may be inserted or removed in this position. (See Figure 1.) NOTE: To minimize cycle time during normal operation, the Aeroquip ProCrimp 1390 crimp machine can be programmed to stop retracting before it has fully retracted. This reduces the crimping cycle time. The die cage may not be able to be removed. Pressing and holding RETRACT will always bring the cylinder to the full retract position. See instructions on Page 5.

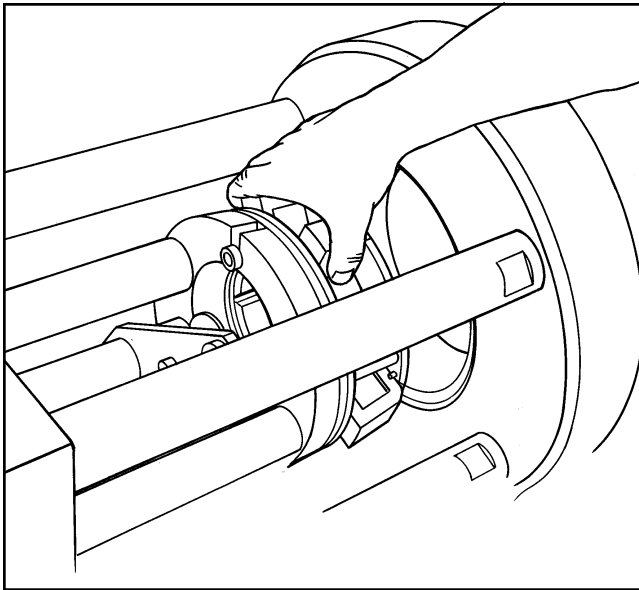

Figure 1

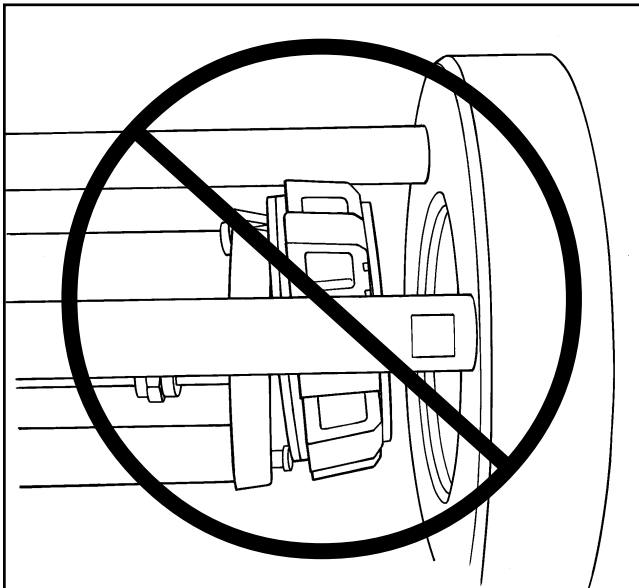

Figure 2



CAUTION: Figure 2 shows a die cage that is installed improperly. When inserted properly, the cage is flush against the pressure plate. If the die cage is at an angle to the pressure plate, lift it up and realign properly.

Operating the Keypad (Figure 3)

1. The DISPLAY shows the three-digit setting that will determine the crimp diameter. The DISPLAY number itself is a relative number, not a crimp diameter. The ratio of crimp diameter change to the DISPLAY change is 1 to 1. For example, if you crimp a fitting at a setting of 250, and the crimp diameter is .014 inch too large, you will need to decrease the DISPLAY by 014 to $(250-014) = 236$. A display of 236 should produce the correct crimp diameter.
2. The STORE button is used to store the DISPLAY reading in any of the 10 numbered keys. The green light next to the STORE button will illuminate when you are working in the STORE mode.
3. The ENTER button is used to put any three-digit number into the DISPLAY. The green light next to the ENTER button will illuminate when you are working in the ENTER mode.

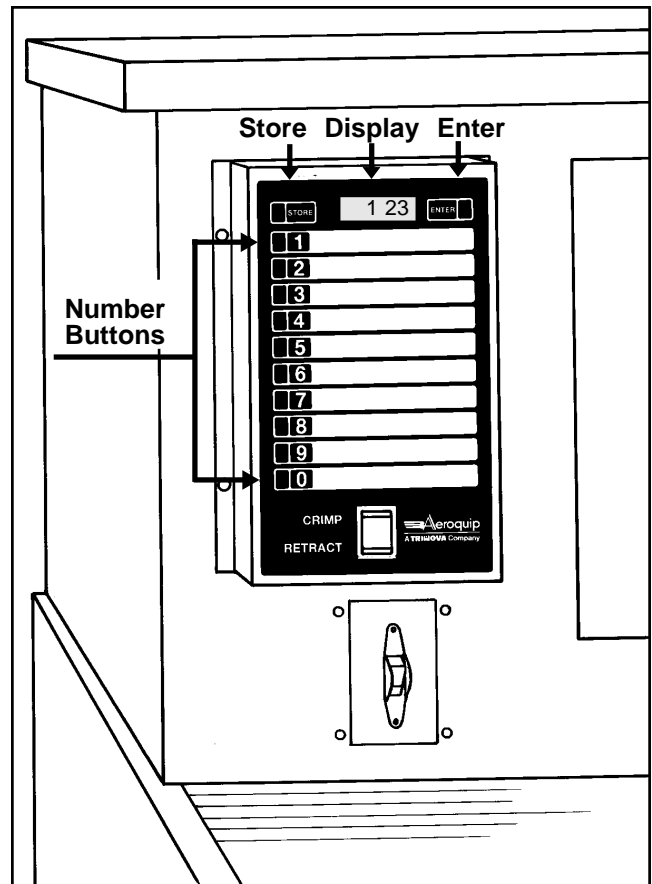

Figure 3

4. The numbered keys have two functions:
 - a. In the ENTER mode, their numeric value is put into the DISPLAY.
 - b. In the STORE mode, they act as 10 different memory locations in which to store a DISPLAY setting.

Entering a Number into the DISPLAY

1. Turn the power control switch below the keypad to the ON position. The DISPLAY will illuminate to show that the power is on.
2. Press the ENTER button. (The green light next to the ENTER button will illuminate.)
3. Press three number buttons. (If more than five seconds elapse between pressing the number buttons, the DISPLAY reverts back to its previous setting.) After the third number is pressed, the DISPLAY will remain and the green light next to the ENTER button will turn off.
4. The FT1390 is now ready to crimp to the DISPLAY setting.

Storing a Number from the DISPLAY as a Preset

1. Enter a three-digit number as described in the procedure above.
2. Press the STORE button. (The green light next to the STORE button will illuminate.)
3. Press and hold down any one of the 10 numerical buttons for three seconds. (After three seconds, the green light next to the pressed button will illuminate, indicating that the DISPLAY has been stored to that button.)

Recalling a Preset into the DISPLAY

1. Make sure that the STORE and ENTER lights are off. (If one is on, it will go off in five seconds if the keypad is left untouched.)
2. Press the numeric button that has the stored setting for a given hose and fitting style. That setting will then be seen in the DISPLAY, and the light next to the numeric button will illuminate.

Programmable Retract Stop

1. Using the Crimp/Retract switch, place the cylinder in the position where you want it to stop during retraction.
2. Press and hold the ENTER button until the green light next to the button turns off (approximately three seconds). The cylinder will now automatically stop retracting at this position until another position is set or until the crimp machine is shut off.

NOTE: Pressing and holding the RETRACT switch will allow the cylinder to fully retract. This will not change or erase the programmable retract stop.

NOTE: Turning the crimp machine off and back on erases the programmable retract stop position.

Adjustable Backstop (Figure 4)

1. Turn off the power to the machine.
2. Insert the die cage.
3. Loosen the thumbscrew on the backstop.
4. Place the fitting against the locator cone. Pushing it too hard will compress the spring, which will affect the accuracy of the position.
5. Slide the backstop to the desired position. (For Match-Mate Plus fittings refer to Figure 5.)
6. Tighten the thumbscrew.
7. Turn the power on.

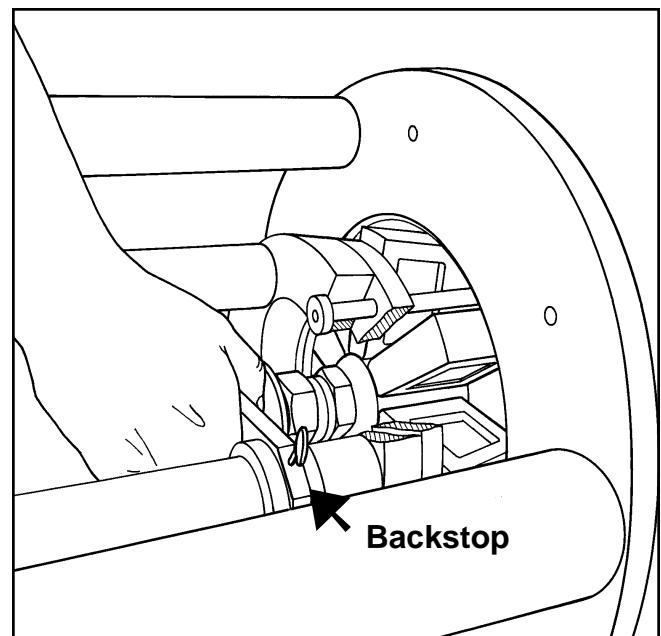

Figure 4

Crimping Procedures



WARNING: Maintain clear distance from all moving parts.

Refer to the current Aeroquip Crimp Specifications bulletin for complete and detailed crimp specification information for each hose and fitting style.

1. Retract the cylinder by pressing the RETRACT switch until the cylinder is fully retracted. Select the proper die cage from the current Aeroquip Crimp Specifications bulletin. Insert the die cage onto the pressure plate. (See Figure 1.)
2. Press the proper PRESET button or key in a value to the DISPLAY. (See Example.) MatchMate Plus and MatchMate BLUE™ target setting charts are available from Aeroquip.
3. Position the fitting in the crimp die cage according to the corresponding figure in the current Aeroquip Crimp Specifications bulletin. (A MatchMate Plus fitting is shown in Figure 5.)
4. To crimp the fitting, press the CRIMP switch or footswitch. The die cage will advance until the fitting is fully crimped (Figures 6 & 7). It will then automatically begin to retract, signifying that the crimp is complete. Release the crimp switch or footswitch. The die cage will automatically retract and stop at the “full retract” position or at the programmable retract position if it has been set.

HINT: Retraction can be halted at any point by momentarily pressing the RETRACT switch or footswitch.

5. Verify the correct crimp diameter.

REMINDER: Full retraction is required for changing die cages.

Example:

Enter the number “500” into the DISPLAY, and start the crimping process. If the dies crimp the fitting, measure the crimp diameter and decrease the DISPLAY setting by the same amount that you wish to decrease the crimp diameter. If the dies don’t touch the fitting, lower the DISPLAY setting by 050 to “450” and crimp the fitting again. If that still isn’t enough, continue to reduce the DISPLAY setting by 050 increments until the dies make contact with the fitting. Then, measure the crimp diameter and decrease the DISPLAY setting by the same amount that you wish to decrease the crimp diameter.

If a display setting of “250”—using GH793-8 hose with TTC fittings—produces a crimp diameter of 1.004 inches, subtract the crimp specification (0.990 inches) from the diameter that you measured ($1.004 - 0.990 = 0.014$). Then, subtract “014” from the DISPLAY setting ($250 - 014 = 236$), and change the DISPLAY to “236.” Crimp the fitting again, and measure the crimp diameter. If the crimp diameter is still too large, repeat this process.

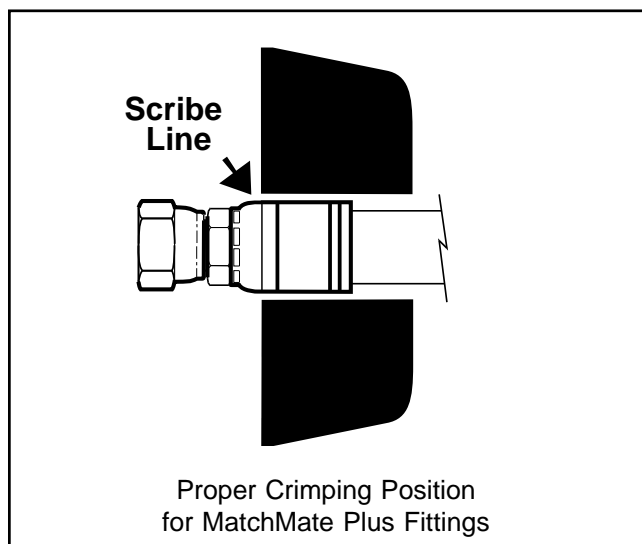

Figure 5

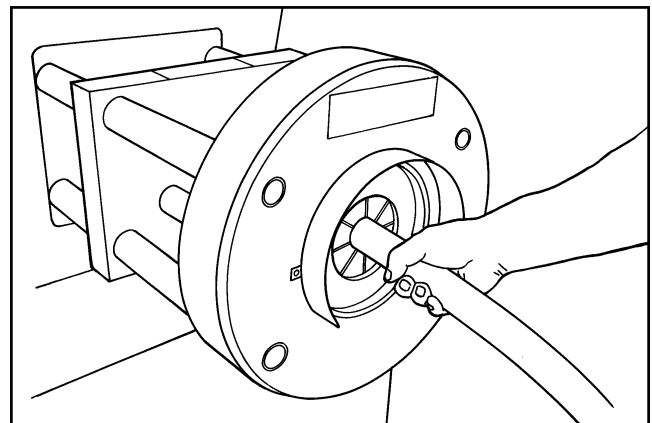

Figure 6

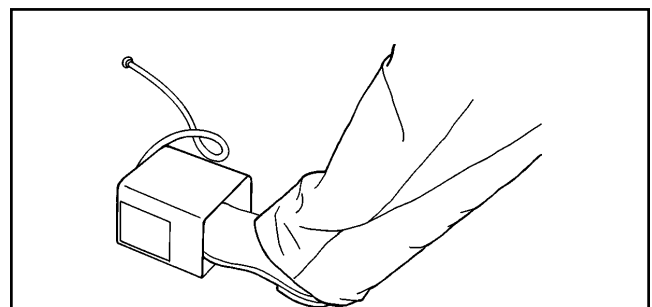

Figure 7

Calibration



WARNING: Maintain clear distance from all moving parts.

The calibration procedure below will calibrate the Aeroquip ProCrimp 1390 crimp machine to the original factory setting. While new machines are calibrated at the factory and will be ready to use upon receipt, this procedure should be followed if the crimp machine has been disassembled or has had components replaced. The procedure requires the use of an FT1307-200-M180 die cage, a 1SB4 socket (or TTC-4 fitting), and a 1SB8 socket (or a TTC-8 fitting).

NOTE: While in the calibration mode, follow the instructions precisely, and press the keys deliberately. If a mistake is made, the calibration procedure must be started over by turning the machine off and then on again.

1. Insert an FT1307-200-M180 die cage.
2. Press the STORE and ENTER buttons simultaneously, and then release. Both button lights will now illuminate and will remain lit until the calibration procedure is finished.
3. Input the value of "210" using the keypad.
4. Center a 1SB4 socket or TTC-4 fitting (without a hose) in the die cage, holding the socket or fitting in place with a pencil or other suitable tool. Crimp the socket by pressing the crimp switch or footswitch until the machine retracts by itself, indicating a completed cycle. Allow the die cage to retract to the "full retract" position.
5. Using a micrometer, measure the crimp diameter. The preferred method is to use the average of the four pairs of indentations.
6. Locate the crimp diameter in Table A, below. Using the keypad, enter in the three-digit DISPLAY reading that corresponds to the crimp diameter.

NOTE: If your crimp diameter falls between the numbers shown in Table A, simply determine or interpolate the DISPLAY reading, since the numbers are a direct ratio.

| Table A for -4 | | Table B for -8 | |
|----------------|-----------------|----------------|-----------------|
| Crimp Diameter | Display Reading | Crimp Diameter | Display Reading |
| 0.670 | 170 | 1.070 | 570 |
| 0.680 | 180 | 1.080 | 580 |
| 0.690 | 190 | 1.090 | 590 |
| 0.700 | 200 | 1.100 | 600 |
| 0.710 | 210 | 1.110 | 610 |
| 0.720 | 220 | 1.120 | 620 |
| 0.730 | 230 | 1.130 | 630 |
| 0.740 | 240 | 1.140 | 640 |

7. Input in the value of "610" using the keypad.
8. Center a 1SB8 socket or TTC-8 fitting (without a hose) in the die cage, holding the socket or fitting in place with a pencil or other suitable tool. Crimp the socket by pressing the crimp switch or footswitch until the machine retracts by itself, indicating a completed cycle. Allow the die cage to retract to the full retract position.
9. Repeat steps 5 and 6 at left, using Table B for the -8 socket.
10. After the three-digit DISPLAY reading in Step 9 is entered, the machine will automatically exit the calibration mode.

Calibration Example:

Crimp a 1SB4 socket, and measure the four crimp diameters around the socket. Let's say, for example, that the diameters measure .692, .693, .694 and .694 inches. To obtain the average diameter, add the four diameters, and divide that sum total by 4.

$$\frac{(.692+.693+.694+.694)}{4} = \frac{2.773}{4} = 0.69325 = 0.693$$

(round to nearest thousandth)

Look at the crimp diameter column in Table A and find your average diameter. If it falls between two numbers, as this one does, interpolate the desired setting. In this case, you would enter 193. If your crimp diameter is .690, you would enter 190; if it is .697, you would enter 197.

Crimp a 1SB8 socket, and measure the four crimp diameters around the socket. This time, let's say that the diameters measure 1.113, 1.115, 1.114 and 1.115 inches. Obtain the average diameter by adding the four diameters and dividing that sum total by 4.

$$\frac{(1.113+1.115+1.114+1.115)}{4} = \frac{4.457}{4} = 1.11425 = 1.114$$

(round to nearest thousandth)

Look at the crimp diameter column in Table B and find your average diameter. If it falls between two numbers, as this one does, interpolate the desired setting. In this case, you would enter 614. If your crimp diameter is 1.110, you would enter 610; if it is 1.119, you would enter 619.

Maintenance Intervals

Die Cage Lubrication

Every 50 crimps..... Relube sliding surfaces of dies

Every 500 crimps Remove old grease and relube

Every 1000 crimps Die cage maintenance
(See below.)

Crimp Ring Maintenance

Every 500 crimps Remove old grease and relube

Every 2000 crimps Remove old grease, inspect for
wear or damage and relube if OK.

Cylinder Plate Bushing Maintenance

Every 2000 crimps Remove old grease, inspect for
wear or damage and relube if OK.

Use NEVER•SEEZ lubricant (Aeroquip Part Number FT1092).

Maintenance Procedures

Machine Maintenance Procedures

1. Sliding surfaces must be kept free of dirt and other abrasive materials.
2. All exposed black metal surfaces should be coated occasionally with a light film of oil to prevent corrosion.
3. Periodically check the oil level in the fluid reservoir of the hydraulic power unit. Maintain the oil level according to the indicator on the top of the reservoir. Add ENERPAC premium hydraulic oil as needed.

NOTE: Completely retract the crimp ring when checking the oil level.

Die Cage Maintenance Procedures

1. Lubricate the die cage. For maximum service, die cages require lubrication at 50-crimp intervals with NEVER•SEEZ (Aeroquip Part Number FT1092). FT1092 is an eight-ounce container that will provide sufficient lubricant for about 5,000 crimps.

Periodically remove NEVER•SEEZ residue that has built up on the sides of the dies and in the crimp ring during the crimping process. Do not allow contaminated NEVER•SEEZ to come into contact with the dies. (This can cause dies to stick to the crimp insert.) NEVER•SEEZ residue becomes contaminated with metal and plating chips and airborne contaminants, which can cause premature wear of the dies and crimp ring.

2. Die cage maintenance should be performed at 1000-crimp intervals or every six months, whichever occurs first. Die cages should be free of grease and debris and inspected for worn or damaged components.

- a. The sliding surface of the dies should appear smooth with no apparent galling. Galled dies must be replaced. Individual dies in a cage can be replaced without replacing all eight dies.
- b. Replace springs that show any sign of damage or collapse such as those which are shorter than the other springs.
- c. The spring plate should appear smooth with no apparent galling. Galled spring plates must be replaced.
- d. Inspect remaining components, and replace those that are badly worn.

Reassemble components, and liberally apply NEVER•SEEZ to the die surface which slides along the spring plate. Torque the die cage bolts to 50 in. -lbs.

Ensure that all dies slide in and out freely.



WARNING: Removal of the cylinder and hydraulic power unit from a crimp machine that is not secured to the floor will cause reduced stability.

Troubleshooting Tips

Remember: The electric motor only runs during the crimping process. The motor energizes when the crimp/retract switch or footswitch is pressed and de-energizes when the cylinder has retracted.

| Symptom | Possible Cause | Corrective Action |
|---|--|--|
| Pump will not start | <ul style="list-style-type: none"> No power or wrong voltage | <ul style="list-style-type: none"> Make sure that the unit is plugged in. Make sure that the power source is on. Make sure that the power voltage is correct. Check for loose wires on the circuit board. Check for loose wires on the CRIMP switch. |
| Motor stalls under load | <ul style="list-style-type: none"> Low voltage | <ul style="list-style-type: none"> Verify that the branch circuit conforms to the electrical specifications on Page 3 of this manual. Remove any extension cords. |
| Electric valve will not operate | <ul style="list-style-type: none"> No power or wrong voltage Low voltage | <ul style="list-style-type: none"> Check for loose wires on the circuit board. Check for loose wires on the CRIMP switch. Make sure that the power voltage is correct. |
| Pump fails to build pressure | <ul style="list-style-type: none"> External leak in system Internal leak in pump Internal leak in valve Internal leak in system component | <ul style="list-style-type: none"> Wipe away spilled oil, and locate the source of leak. If the hose assembly is leaking, tighten or replace it. If the pump or cylinder is leaking, refer to the ENERPAC Repair Parts Sheets. Slight oil seepage of the cylinder is normal. |
| Pump builds less than full pressure | <ul style="list-style-type: none"> Relief valve set low External system leak Internal leak in pump Internal leak in valve Internal leak in system component | <ul style="list-style-type: none"> Refer to the ENERPAC Repair Parts Sheets for possible adjustment or leakage repair. |
| Pump builds full pressure, but cylinder does not move | <ul style="list-style-type: none"> Tie rods may be binding Flow to cylinder blocked | <ul style="list-style-type: none"> Replace the tie rods. Refer to the ENERPAC Repair Parts Sheets. |
| Cylinder will not return | <ul style="list-style-type: none"> Valve malfunction Restricted/blocked Tie rods may be binding Die cage may be binding | <ul style="list-style-type: none"> Refer to the ENERPAC Repair Parts Sheet for valve or cylinder repair. Replace the tie rods. Check the die cage and crimp ring for damage, and repair or replace them if necessary. Lubricate the die cage per the maintenance procedures on Page 8. Lubricate the tie rod bushings per the maintenance procedures on Page 8. |
| Crimp diameters change | <ul style="list-style-type: none"> Incorrect hose/fitting combination Incorrect die cage Die cage or crimp insert damage Transducer is loose Loose crimp machine components External damage to crimp machine Insufficient lubrication on dies | <ul style="list-style-type: none"> Verify the correct hose/fitting combination. Verify the correct die cage. Repair or replace the damaged components. Tighten the transducer and brackets, and then recalibrate them if necessary. Tighten any loose bolts or screws Lubricate the die cage per the maintenance procedures on Page 8. Lubricate the tie rod bushings per the maintenance procedures on Page 8. |
| DISPLAY blinks | <ul style="list-style-type: none"> Loose or broken wires | <ul style="list-style-type: none"> Tighten any wires that may have become loose on the circuit board, pump electrical enclosure, or CRIMP switch. |

If the symptom appears to be solely pump or cylinder related, refer to the ENERPAC Repair Parts Sheets.

Any electrical checks must be done by a qualified electrician.

Refill oil reservoir with ENERPAC premium hydraulic oil only (ENERPAC P/N H-F-101).

Crimp Machine Parts Breakdown

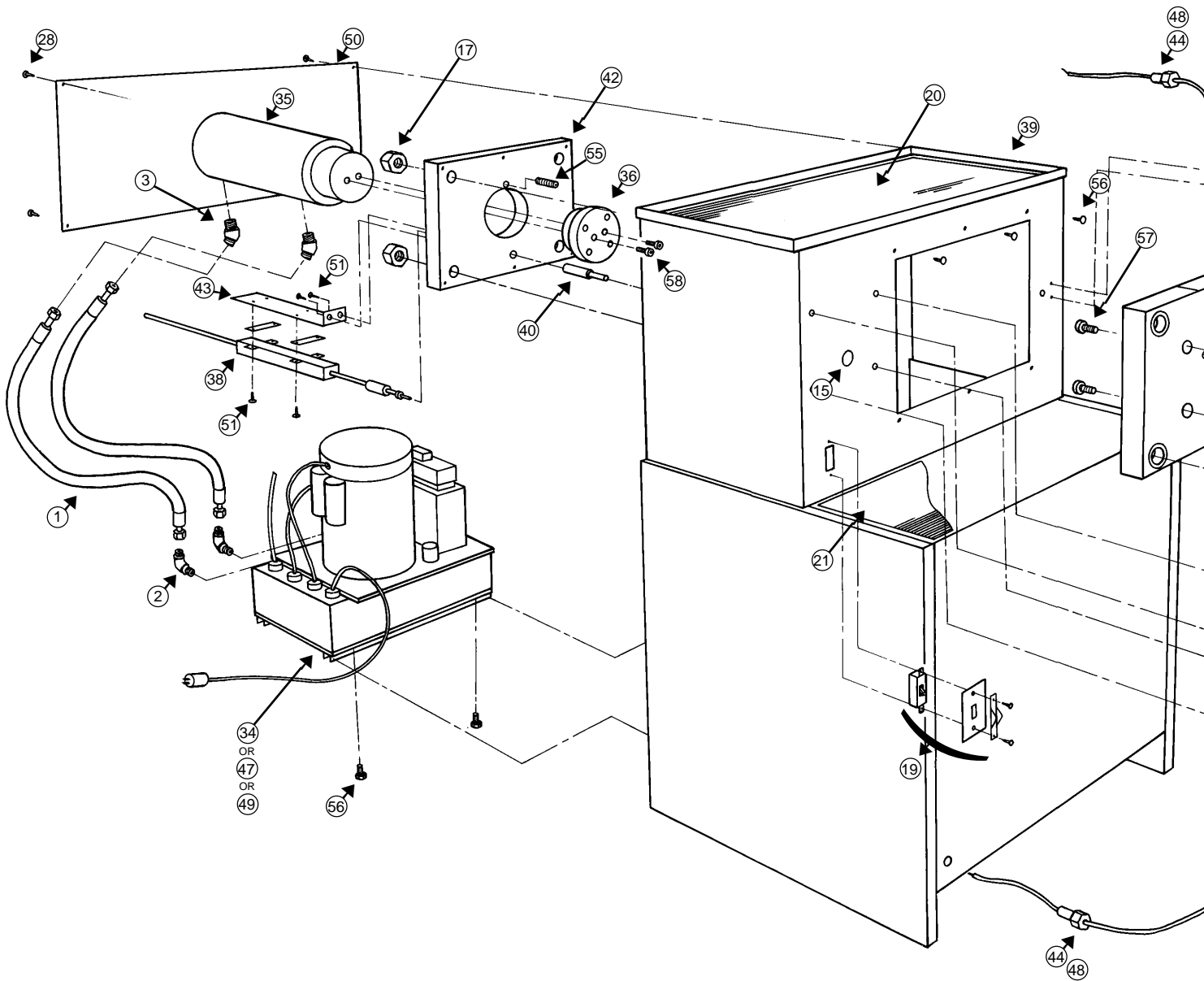

| Detail | Part Number | Description | Qty | Detail | Part Number | Description | Qty |
|--------|-----------------|--|-----|--------|---------------|---|-----|
| 1 | 1C02217GGG0310A | Hose Assembly | 2 | 17 | FT1340-2-2-20 | Nut | 4 |
| 2 | FF2032T0606S | 90° Adapter (may have all 45° adapters) | 2 | 18 | FT1340-2-2-23 | Crimp Ring | 1 |
| 3 | FF2093T0606S | 45° Adapter | 2 | 19 | FT1340-2-5-1 | Motor Starter Switch | 1 |
| 4 | FF9339-08-24S | 1/2-13 X 1.50 SHCS | 4 | 20 | FT1340-3-2 | Tray Matting (2 pieces) | 1 |
| 5 | FT1289-2-2-14 | Retaining Ring | 1 | | FT1340-3-4 | Backstop Assembly (includes Details 22 through 27) | 1 |
| 6 | FT1289-2-2-15 | Crimp Ring Insert | 1 | 22 | FT1340-3-4-1 | Shoulder Bolt | 1 |
| 7 | FT1289-3-13 | Push Rod | 4 | 23 | FT1340-3-4-2 | Spring | 1 |
| 8 | FT1289-3-15 | Pressure Plate | 1 | 24 | FT1340-3-4-3 | Locator Plate | 1 |
| 9 | FT1289-3-46 | Plate | 1 | 25 | FT1340-3-4-4 | Bronze Bushing | 1 |
| 10 | FT1289-3-60 | Caution Decal | 1 | 26 | FT1340-3-4-5 | Thumb Screw | 1 |
| 11 | FT1289-3-62 | Guard | 1 | 27 | FT1340-3-4-6 | Locator Cone | 1 |
| 12 | FT1303-3-76 | Shoulder Bolt | 2 | 28 | FT1360-3-8 | 1/4-20 X .38 BHCS | 4 |
| 13 | FT1330-3-64 | Attention Decal | 1 | 29 | FT1380-3-3 | 3-Position Switch | 1 |
| 14 | FT1330-3-68 | Work Lamp | 1 | 30 | FT1380-3-6 | Key Pad | 1 |
| 15 | FT1330-3-7 | Rubber Grommet | 1 | 31 | FT1380-3-7 | Electrical Enclosure | 1 |
| 16 | FT1340-2-2-19 | Tie Bar | 4 | 32 | FT1380-3-18 | #4-40x.188 lg. SHCS | 4 |

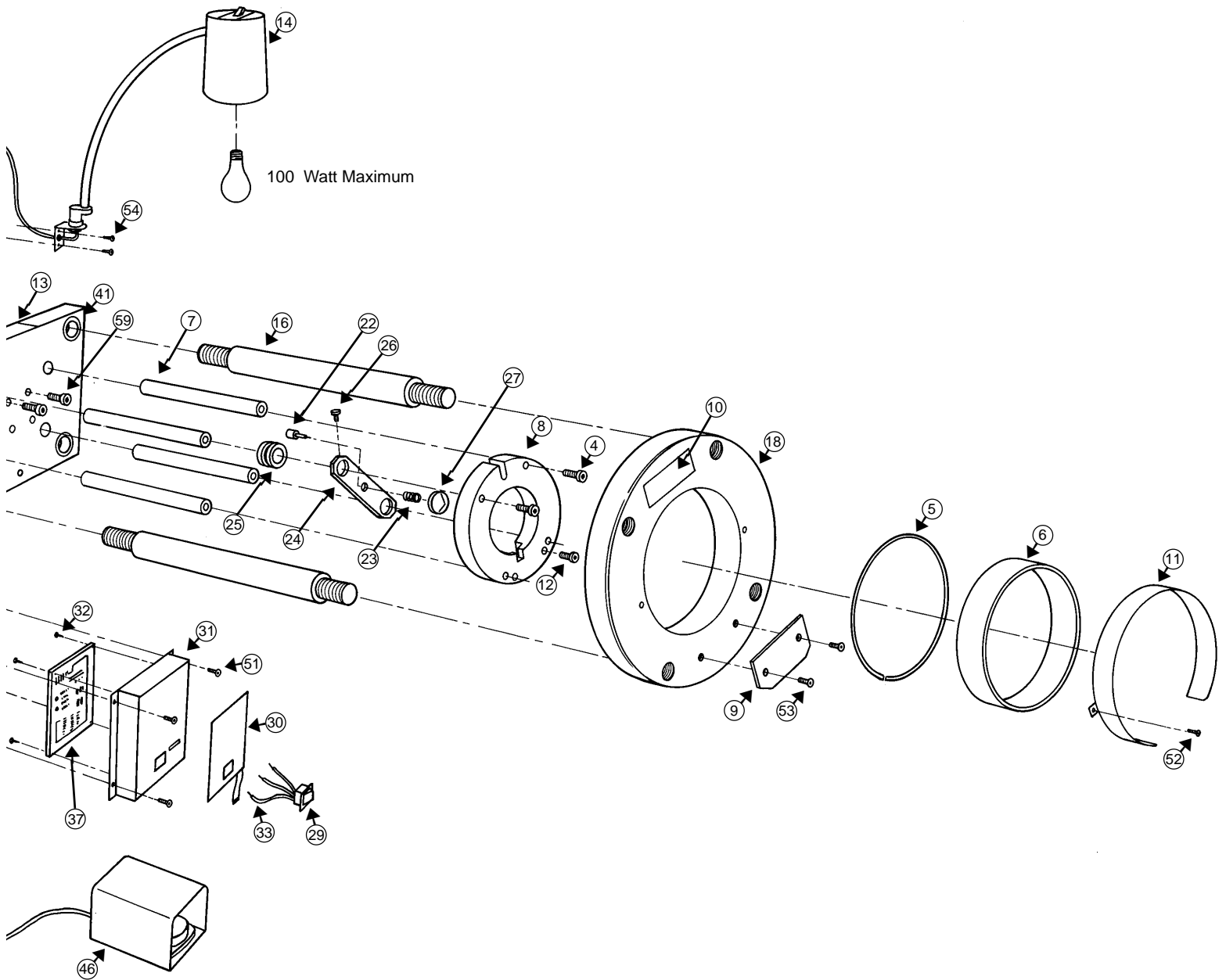

| Detail | Part Number | Description | Qty |
|--------|-------------|---|-----|
| 33 | FT1380-3-31 | Insulated Wire | 3 |
| 34 | FT1390-3-1 | Hydraulic Power Unit 115VAC 60HZ | 1 |
| 35 | FT1390-3-2 | Hydraulic Cylinder | 1 |
| 36 | FT1390-3-3 | Cylinder Adapter | 1 |
| 37 | FT1390-3-4 | Control Card | 1 |
| 38 | FT1390-3-5 | Transducer (includes clips and rod adapter) | 1 |
| 39 | FT1390-3-6 | Base (includes electrical box) | 1 |
| 40 | FT1390-3-7 | Transducer Rod Extension | 1 |
| 41 | FT1390-3-8 | Push Block | 1 |
| 42 | FT1390-3-9 | Cylinder Mounting Plate | 1 |
| 43 | FT1390-3-10 | Transducer Bracket | 1 |
| 44 | FT1390-3-11 | Decal, Serialized (Not Shown) | 1 |
| 44 | FT1390-3-14 | Compression Connector | 3 |
| 45 | FT1390-3-15 | Compression Connector | 1 |
| 46 | FT1390-3-16 | Foot Switch | 1 |

| Detail | Part Number | Description | Qty |
|--------|------------------|--------------------------------------|-----|
| 47 | FT1390-3-17 | Hydraulic Power Unit 208-240VAC 60HZ | 1 |
| 48 | FT1390-3-18 | Locknut | 4 |
| 49 | FT1390-3-19 | Hydraulic Power Unit 230VAC 50HZ | 1 |
| 50 | FT1390-3-6-2 | Rear Panel | 2 |
| 51 | 222003-1-8-6S | #8-32 X .38 SHCS | 8 |
| 52 | FF9339-0108-06S | #8-32 X .38 BHCS | 2 |
| 53 | FF90258-0110-06S | #10-32 X .38 FHCS | 2 |
| 54 | FF9156-0110-08S | #10-32 X .50 BHCS | 2 |
| 55 | FF9197-06-08S | 3/8-16 X .50 SHSS | 1 |
| 56 | 222003-6-12S | 3/8-16 X 0.75 SHCS | 10 |
| 57 | 222003-6-40S | 3/8-16 X 2.50 SHCS | 4 |
| 58 | 222003-8-56S | 1/2-13 X 3.50 SHCS | 2 |
| 59 | 222003-6-32S | 3/8-16 X 2.00 SHCS | 4 |
| 60 | 222003-1-10-6S | #10-24 x .38 SHCS | 2 |
| | FT1092 | NEVER-SEEZ (not shown) | 1 |
| | JA570 | ProCrimp 1390 Decal (not shown) | 1 |
| | JA146C | Aeroquip Decal (not shown) | 2 |

FT1307 Die Cage Parts Breakdown

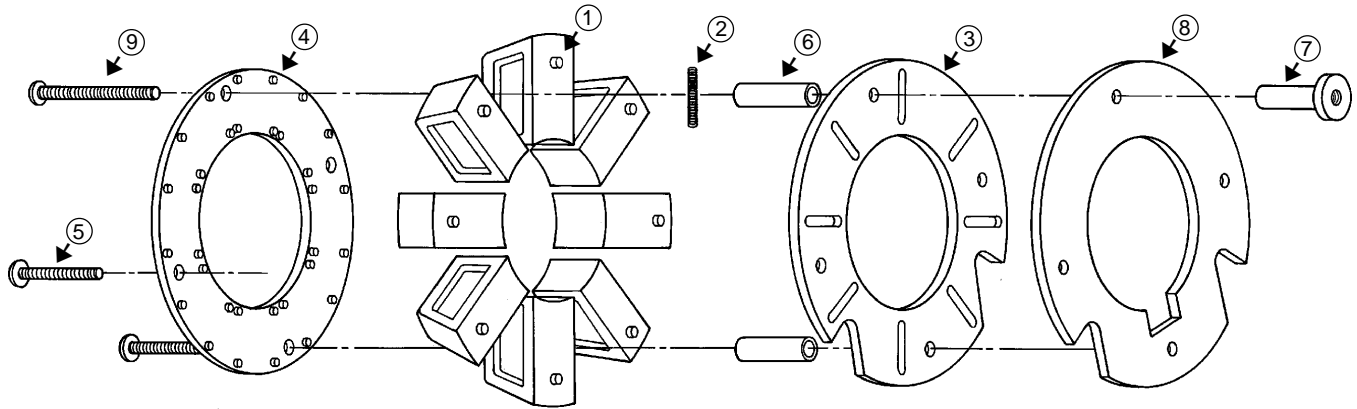

| Detail | Qty | Part Number | Description |
|--------|------|---------------|-----------------------------|
| 1 | 8 pc | 21057-7 | Roll Pin .25 dia x .62 long |
| 2 | 8 pc | FT1209-2-9-7 | Spring |
| 3 | 1 pc | FT1307-2-9-3 | Spring Plate |
| 4 | 1 pc | FT1307-2-9-4 | Front Plate |
| 5 | 3 pc | FT1307-2-9-5 | BHCS 5/16-18x2.56 long |
| 6 | 4 pc | FT1307-2-9-6 | Spacer |
| 7 | 1 pc | FT1307-2-9-7 | Nut |
| 8 | 1 pc | FT1307-2-9-8 | Back Plate |
| 9 | 1 pc | FT1307-2-9-10 | BHCS 5/16-18x3.00 long |

FT1209 Die Cage Parts Breakdown

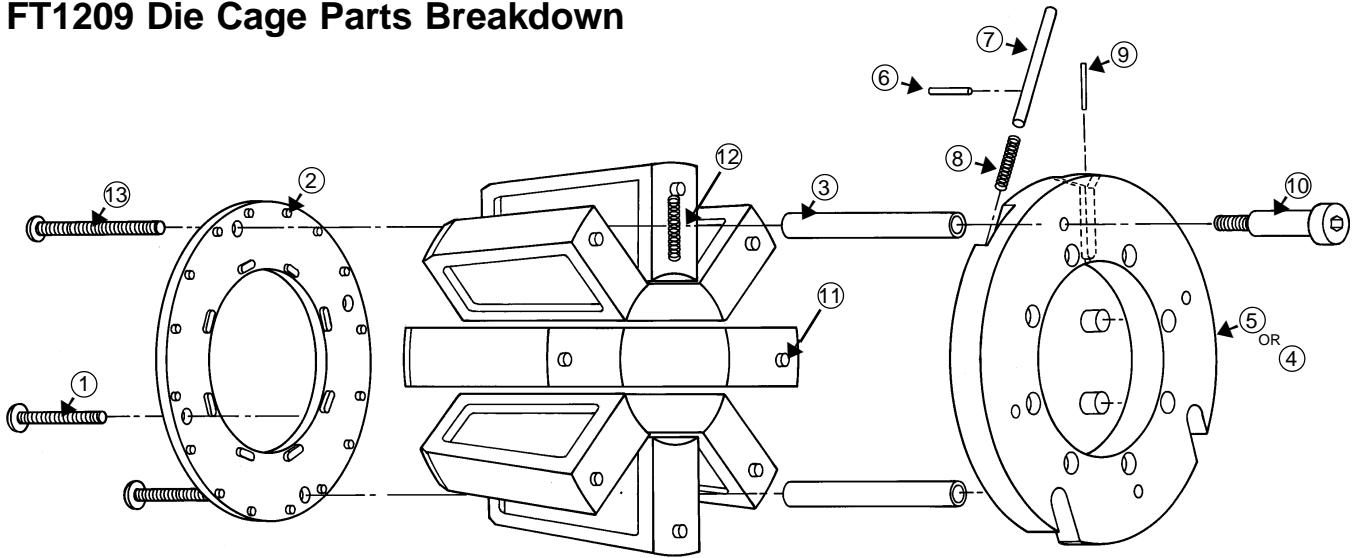

| Detail | Qty | Part Number | Description |
|--------|------|----------------|---|
| 1 | 3 pc | FT1209-2-9-1 | BHCS 5/16-18x3.90 long |
| 2 | 1 pc | FT1209-2-9-2 | Front Plate |
| 3 | 4 pc | FT1209-2-9-3 | Spacer |
| 4 | 1 pc | FT1209-2-9-4 | Back Plate Assembly (Details 5 through 9) |
| 5 | 1 pc | FT1209-2-9-4-1 | Back Plate |
| 6 | 2 pc | FT1209-2-9-4-2 | Roll Pin .09 dia x .50 long |
| 7 | 2 pc | FT1209-2-9-4-3 | Rod |
| 8 | 2 pc | FT1209-2-9-4-4 | Spring |
| 9 | 2 pc | FT1209-2-9-4-5 | Roll Pin .125 dia x .75 long |
| 10 | 1 pc | FT1209-2-9-5 | Shoulder Screw |
| 11 | 8 pc | 21057-7 | Roll Pin .25 dia x .62 long |
| 12 | 1 pc | FT1209-2-9-7 | Spring |
| 13 | 1 pc | FT1209-2-9-8 | BHCS 5/16-18x3.50 long |

Electrical Schematic for FT1390-115 (115V model)

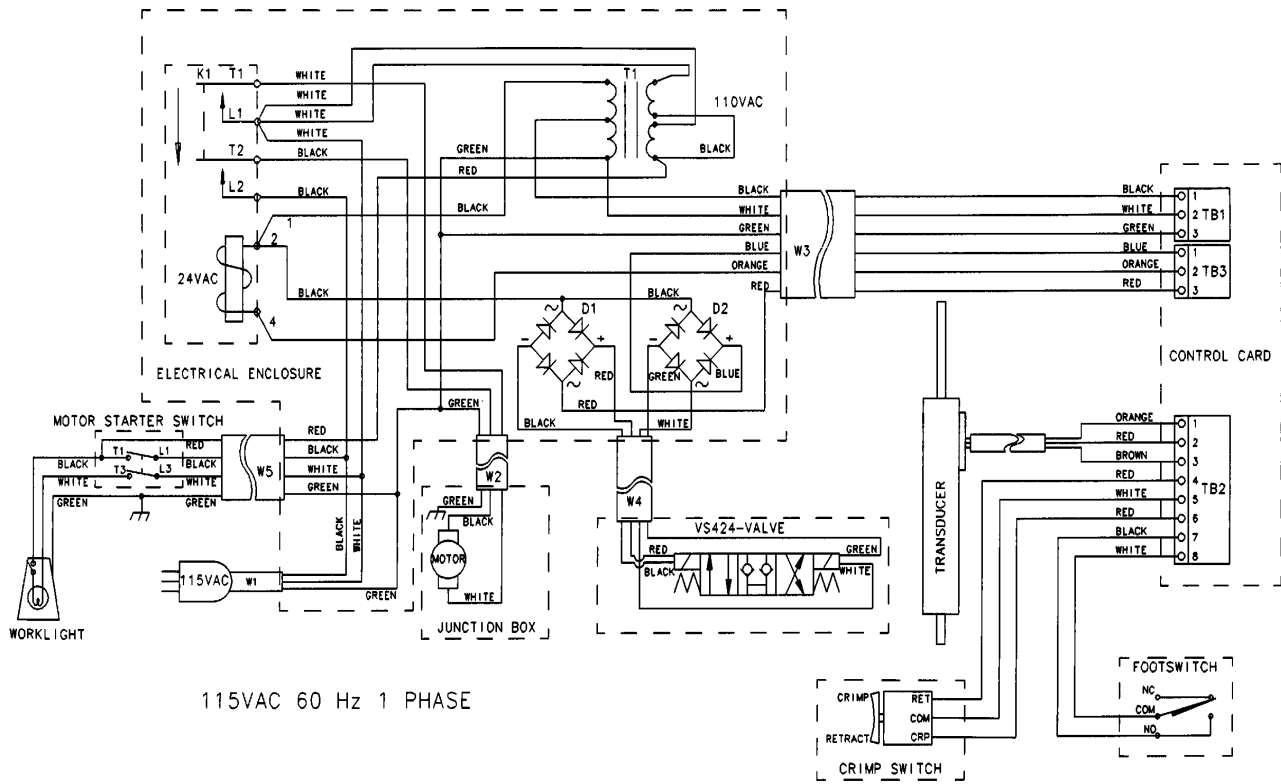

Electrical Schematic for FT1390-230 (230V model)

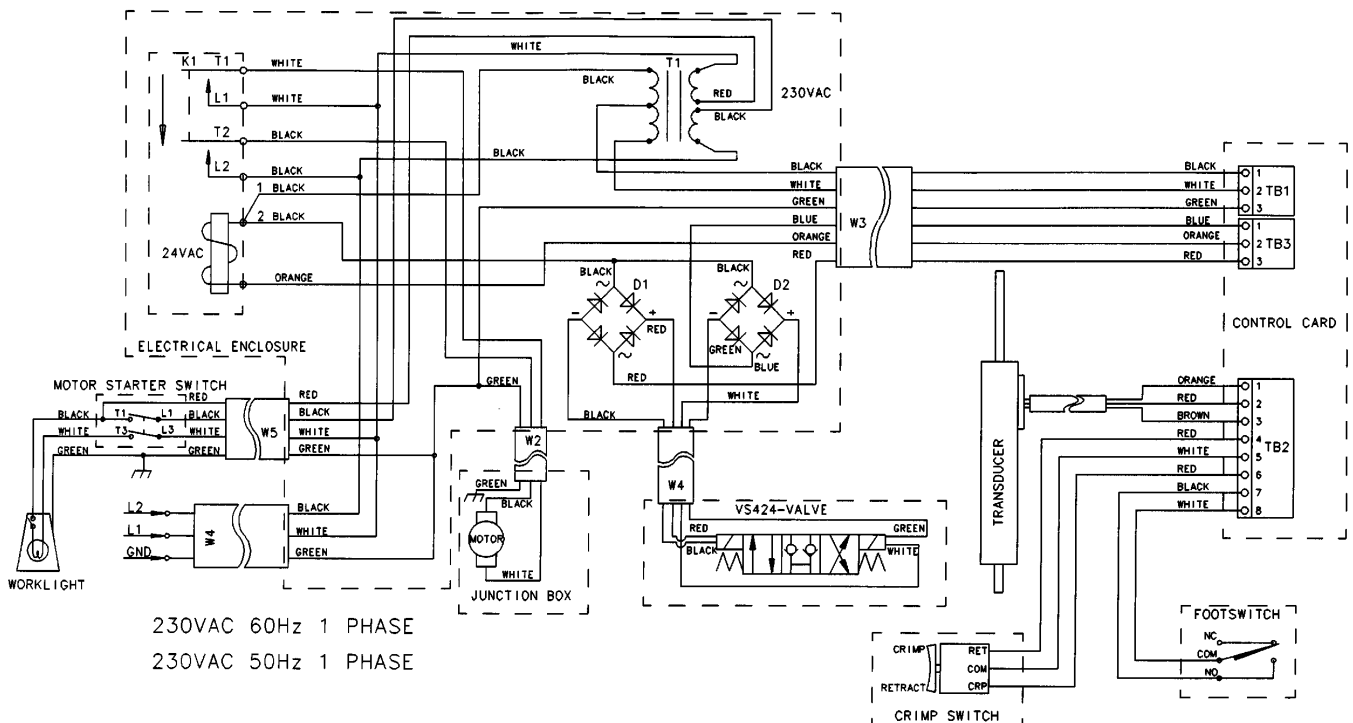

Electrical Schematic – Terminal Blocks and Pin Numbers (115V and 230V models)

| Terminal Block | Pin Number | Voltage | Wire Color | Description |
|----------------|------------|--------------------|------------|---------------------|
| TB1 | 1 | +12V AC | Black | From transformer |
| TB1 | 2 | +0V AC | White | From transformer |
| TB1 | 3 | None | Green | To earth ground |
| TB2 | 1 | +4.04V DC | Orange | To transducer |
| TB2 | 2 | +4.04 to 0.04V DC* | Red | To transducer |
| TB2 | 3 | +0.04V DC | Brown | To transducer |
| TB2 | 4 | +5V DC | Red | Crimp switch |
| TB2 | 5 | 0V DC | White | Switch common |
| TB2 | 6 | +5V DC | Red | Retract switch |
| TB2 | 7 | +5V DC | Black | Footswitch |
| TB2 | 8 | 0V DC | White | Footswitch common |
| TB3 | 1 | +24V AC | Blue | To retract solenoid |
| TB3 | 2 | +24V AC | Orange | To motor contractor |
| TB3 | 3 | +24V AC | Red | To advance solenoid |

*The voltage at TB2 pin 2 varies between 4.04V DC and 0.04V DC, depending on the position of the cylinder.

Hydraulic Schematic

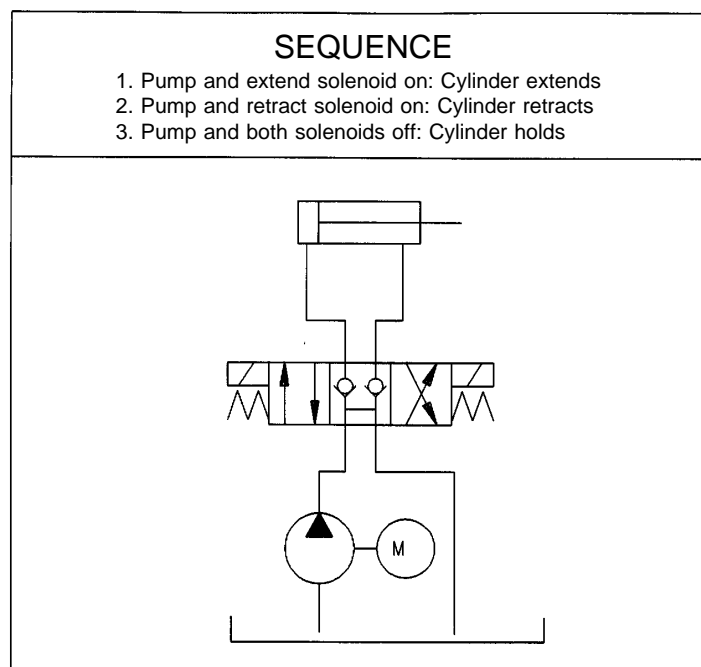



AMERICAS INDUSTRIAL DIVISION

1695 Indian Wood Circle
P.O. Box 700
Maumee, OH 43537-0700
Phone: 419-891-5100
Fax: 419-891-7890

<http://www.aeroquip.com>

Specifications subject to change without notice.
Aeroquip products are protected by patents internationally